

User's guide

SFA-5000

SFA-10000

Absolute draw-wire encoder

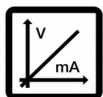

Analogue version



lika

Smart encoders & actuators

This publication was produced by Lika Electronic s.r.l. 2015. All rights reserved. Tutti i diritti riservati. Alle Rechte vorbehalten. Todos los derechos reservados. Tous droits réservés.

This document and information contained herein are the property of Lika Electronic s.r.l. and shall not be reproduced in whole or in part without prior written approval of Lika Electronic s.r.l. Translation, reproduction and total or partial modification (photostat copies, film and microfilm included and any other means) are forbidden without written authorisation of Lika Electronic s.r.l.

The information herein is subject to change without notice and should not be construed as a commitment by Lika Electronic s.r.l. Lika Electronic s.r.l. reserves the right to make all modifications at any moments and without forewarning.

This manual is periodically reviewed and revised. As required we suggest checking if a new or updated edition of this document is available at Lika Electronic s.r.l.'s website. Lika Electronic s.r.l. assumes no responsibility for any errors or omissions in this document. Critical evaluation of this manual by the user is welcomed. Your comments assist us in preparation of future documentation, in order to make it as clear and complete as possible. Please send an e-mail to the following address info@lika.it for submitting your comments, suggestions and criticisms.

The logo for Lika Electronic s.r.l. consists of the word "lika" in a bold, lowercase, sans-serif font. The letters are black and set against a white background.

General contents



User's guide.....	1
General contents.....	3
Typographic and iconographic conventions.....	4
Preliminary information.....	5
1 Safety summary.....	6
1.1 Safety.....	6
1.2 Electrical safety.....	6
1.3 Mechanical safety.....	7
2 Identification.....	8
3 Mechanical installation.....	9
3.1 Overall dimensions.....	9
3.2 Mounting instructions.....	10
3.3 Useful information.....	11
3.4 Maintenance.....	11
4 Electrical connection.....	12
4.1 Cable and connectors connections.....	12
4.2 A8 cable specifications.....	12
4.3 M12 5-pin connector specifications.....	13
4.4 Connection of the shield.....	13
4.5 Ground connection.....	13
4.6 Output circuits.....	14
4.6.1 Analogue current output description.....	14
4.6.2 Analogue voltage output description.....	14
4.6.3 Output signals description.....	14
4.6.4 Input signals description.....	15
4.6.5 Fault output (TI1 order code only).....	15
4.6.5.1 Fault output connected to a PLC input.....	15
4.6.5.2 Fault output connected to a relay.....	16
4.7 Recommended circuit.....	17
4.7.1 Current analogue output.....	17
4.7.2 Voltage analogue output.....	17
5 TEACH-IN procedure.....	18
5.1 Commissioning.....	18
5.2 OVERRUN function.....	20
5.2.1 Overrun function with TI1 order code.....	20
5.2.2 Overrun function with TV1 and TV2 order codes.....	21
5.3 Aborting the TEACH-IN procedure.....	21
5.4 Restoring the factory default settings.....	22
5.5 Function of the LEDs.....	22
5.6 Times and functions.....	23

Typographic and iconographic conventions

In this guide, to make it easier to understand and read the text the following typographic and iconographic conventions are used:

- parameters are coloured in **GREEN**;
- alarms are coloured in **RED**;
- states are coloured in **FUCSIA**.

Some icons in the pages are expressly designed to highlight the parts of the text which are of great interest and significance for the user. Sometimes they are used to warn against dangers or potential sources of danger arising from the use of the device. You are advised to follow strictly the instructions given in this guide in order to guarantee the safety of the user and ensure the performance of the device. In this guide the following symbols are used:

	This icon, followed by the word WARNING , is meant to highlight the parts of the text where information of great significance for the user can be found: user must pay the greatest attention to them! Instructions must be followed strictly in order to guarantee the safety of the user and a correct use of the device. Failure to heed a warning or comply with instructions could lead to personal injury and/or damage to the unit or other equipment.
	This icon, followed by the word NOTE , is meant to highlight the parts of the text where important notes needful for a correct and reliable use of the device can be found. User must pay attention to them! Failure to comply with instructions could cause the equipment to be set wrongly: hence a faulty and improper working of the device could be the consequence.
	This icon is meant to highlight the parts of the text where suggestions useful for making it easier to set the device and optimize performance and reliability can be found. Sometimes this symbol is followed by the word EXAMPLE when instructions for setting parameters are accompanied by examples to clarify the explanation.

Preliminary information

This guide is designed to provide the most complete and exhaustive information the operator needs to correctly and safely install and operate the **SFA-5000 and SFA-10000 absolute draw-wire encoders with analogue interface**.

SFA-5000 / SFA-10000 cable-pulling encoder is aimed at speed and position measurements and controls in a variety of industrial applications through the movement of a **5,000 mm (196.85") or 10,000 mm (393.7")** stainless steel wire. The typical back and forth travel of the moving equipment causes the wire to reel and unreel and thus the linear movement to be converted into a rotative motion detected by the encoder which is coupled to the drum.

Two buttons located in the enclosure (or two external inputs, as an alternative) allow to easily set the initial and the final limits of the application stroke, then the available analogue range will be scaled automatically within the set limits.

SFA-5000 / SFA-10000 is available in the following range of voltage and current analogue signals: 0 to 5V (TV1 order code), 0 to 10V (TV2 order code), 4 to 20mA (I1 order code).

1 Safety summary



1.1 Safety

- Always adhere to the professional safety and accident prevention regulations applicable to your country during device installation and operation;
- installation and maintenance operations have to be carried out by qualified personnel only, with power supply disconnected and stationary mechanical parts;
- device must be used only for the purpose appropriate to its design: use for purposes other than those for which it has been designed could result in serious personal and/or the environment damage;
- high current, voltage and moving mechanical parts can cause serious or fatal injury;
- warning ! Do not use in explosive or flammable areas;
- failure to comply with these precautions or with specific warnings elsewhere in this manual violates safety standards of design, manufacture, and intended use of the equipment;
- Lika Electronic assumes no liability for the customer's failure to comply with these requirements.



1.2 Electrical safety

- Turn OFF power supply before connecting the device;
- connect according to explanation in the "Electrical connection" section;
- in compliance with 2004/108/EC norm on electromagnetic compatibility, following precautions must be taken:
 - before handling and installing the equipment, discharge electrical charge from your body and tools which may come in touch with the device;
 - power supply must be stabilized without noise; install EMC filters on device power supply if needed;
 - always use shielded cables (twisted pair cables whenever possible);
 - avoid cables runs longer than necessary;
 - avoid running the signal cable near high voltage power cables;
 - mount the device as far as possible from any capacitive or inductive noise source; shield the device from noise source if needed;
 - to guarantee a correct working of the device, avoid using strong magnets on or near by the unit;
 - minimize noise by connecting the shield and/or the connector housing and/or the frame to ground. Make sure that ground is not affected by



noise. The connection point to ground can be situated both on the device side and on user's side. The best solution to minimize the interference must be carried out by the user.



1.3 Mechanical safety

- Install the device following strictly the information in the "Mechanical installation" section;
- mechanical installation has to be carried out with stationary mechanical parts;
- do not disassemble the unit;
- do not tool the unit;
- delicate electronic equipment: handle with care; do not subject the device to knocks or shocks;
- respect the environmental characteristics of the product;
- we suggest installing the unit providing protection means against waste, especially swarf as turnings, chips, or filings; should this not be possible, please make sure that adequate cleaning measures are in place in order to prevent the wire from jamming;
- to avoid failures, never exceed the maximum measuring length and prevent the wire from tangling up;
- never release the wire freely, always help the wire wind properly: risk of personal injury and/or equipment damage;
- always keep the wire aligned not to damage the equipment;
- the stroke per turn of the draw-wire unit is 200 mm (7.874").

2 Identification

Device can be identified through the **order code** and the **serial number** printed on the label applied to its body. Information is listed in the delivery document too. Please always quote the order code and the serial number when reaching Lika Electronic. For any information on the technical characteristics of the product refer to the technical catalogue.



Warning: encoders having order code ending with "/Sxxx" may have mechanical and electrical characteristics different from standard and be supplied with additional documentation for special connections (Technical Info).

3 Mechanical installation



WARNING

Installation has to be carried out by qualified personnel only, with power supply disconnected and mechanical parts compulsorily in stop.

3.1 Overall dimensions

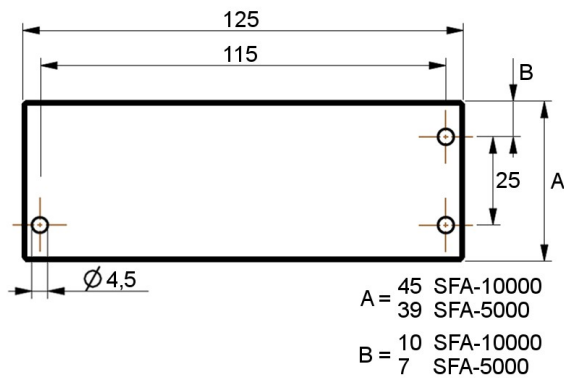
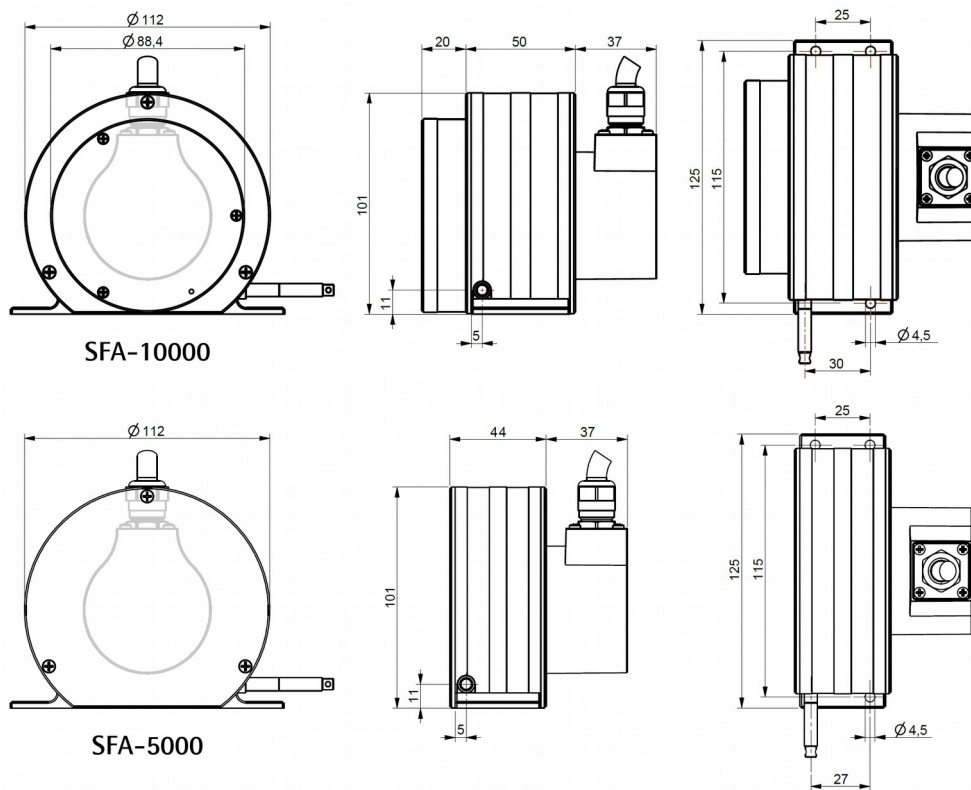

Values are expressed in mm

3.2 Mounting instructions

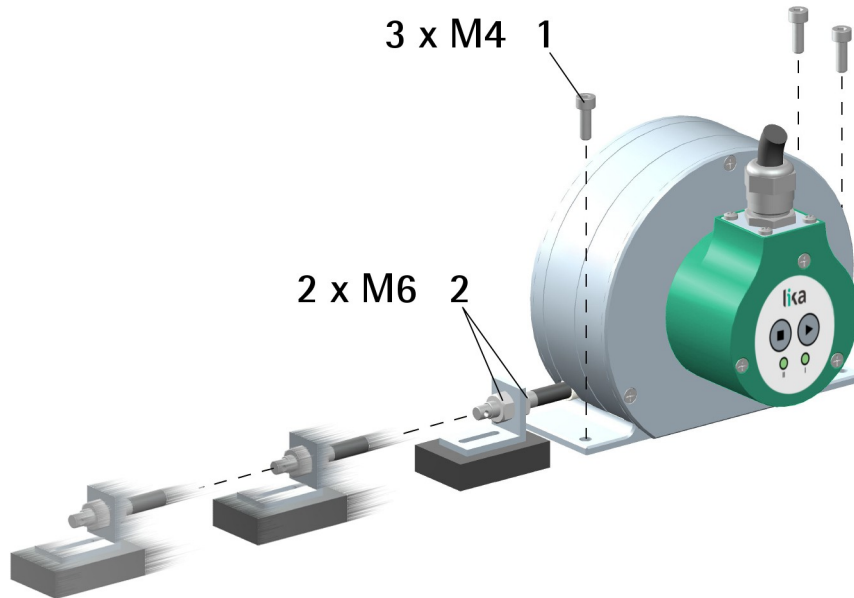

- Fasten the draw-wire unit onto a fixed support using three M4 screws **1**;
- remove the transport safety wire that pins the end of the measuring wire;
- fix the end of the measuring wire to the moving unit using the provided M6 nuts **2**.



WARNING

We suggest installing the unit providing protection means against waste, especially swarf as turnings, chips, or filings; should this not be possible, please make sure that adequate cleaning measures are in place in order to prevent the wire from jamming.

To avoid irreparable failures, never exceed the maximum measuring length and prevent the wire from tangling up.

Never release the wire freely, always help the wire wind properly: risk of personal injury and/or equipment damage.

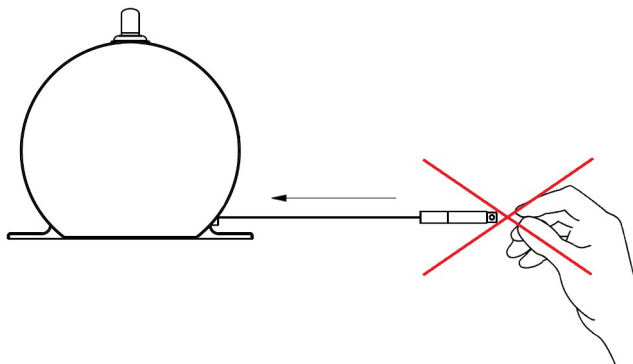

Always keep the wire aligned not to damage the equipment (maximum deviation: 3°).

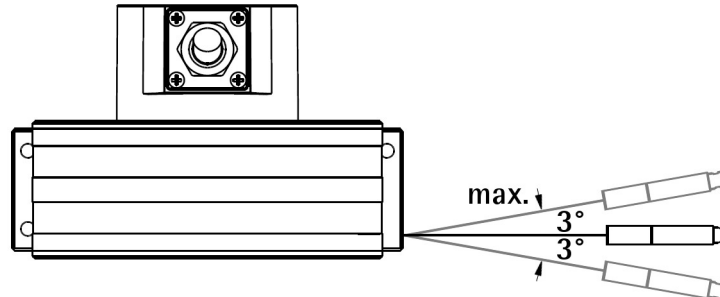

3.3 Useful information

The stroke per turn is 200 mm (7.874"), thus the maximum number of turns is 25 for SFA-5000 and 50 for SFA-10000.

The draw-wire encoder is shipped with default values: the START position begins after the wire is unwound 50 mm (they are calculated starting from wire fully wound) and the analogue value in the first 50 mm is the low limit overrun value; the analogue range is scaled in a 5000 mm travel for SFA-5000; in a 10000 mm travel for SFA-10000. Positive counting by unwinding the wire.

3.4 Maintenance

The measuring system does not need any particular maintenance; anyway it has to be handled with the utmost care as any delicate electronic equipment. From time to time we recommend the following operations:

- the unit and the wire have to be cleaned regularly using a soft and clean cloth to remove dust, chips, moisture etc.; do not use oil to clean the wire.

4 Electrical connection



WARNING

Electrical connection has to be carried out by qualified personnel only, with power supply disconnected and mechanical parts compulsorily in stop.

4.1 Cable and connectors connections

Function	A8 cable	M12 5-pin
+Iout / +Vout	Brown	1
+13Vdc +30Vdc	Red	2
0Vdc	Black	3
START ►	Pink	4
STOP ■	Green	5
0Vdc analogue	White	-
FAULT ¹	Blue	-
Shielding	Shield	Case

¹ Current analogue output only (TI1 order code, see the "4.6.5 Fault output (TI1 order code only)" section on page 15)

4.2 A8 cable specifications

Model	: LIKA A8 cable
Cross section	: 4 x 2 x 0.25 mm ² (24 AWG)
Jacket	: flame retardant PVC
Shield	: tinned copper braid, coverage ≥ 75%
Outer diameter	: 7.0 ± 0.15 mm (0.276" ± 0.006")
Min. bending radius	: 15 mm (0.59")
Work temperature	: -15°C +80°C (+5°F +176°F)
Conductor resistance	: ≤ 78.5 Ω/km

4.3 M12 5-pin connector specifications

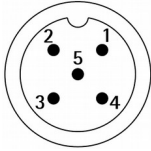

Male
Frontal side
A coding

4.4 Connection of the shield

For signals transmission always use shielded cables. The cable shielding must be connected properly to the metal ring nut **3** of the connector in order to ensure a good earthing through the frame of the device. To do this disentangle and shorten the shielding **1** and then bend it over the part **2**; finally place the ring nut **3** of the connector. Be sure that the shielding **1** is in tight contact with the ring nut **3**.

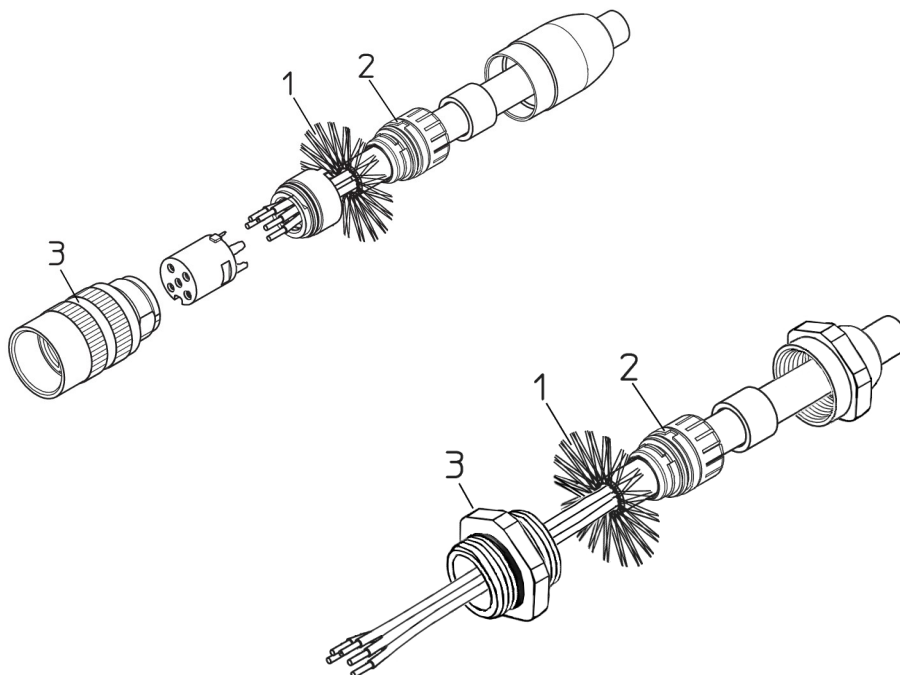

4.5 Ground connection

Minimize noise by connecting the shield and/or the connector housing and/or the frame to ground. Make sure that ground is not affected by noise. The connection point to ground can be situated both on the device side and on

user's side. The best solution to minimize the interference must be carried out by the user. You are advised to provide the ground connection as close as possible to the encoder.

4.6 Output circuits

4.6.1 Analogue current output description

- Out **T11**: min quote = 4mA, max quote = 20mA

Increment per step (encoder resolution):

T11	0.366 μ A
------------	---------------

4.6.2 Analogue voltage output description

- Out **TV1**: min quote = 0 V, max quote = 5 V
- Out **TV2**: min quote = 0 V, max quote = 10 V

Increment per step (encoder resolution):

TV1	0.076 mV
TV2	0.153 mV

4.6.3 Output signals description

- **+Iout**: current analogue output;
- **+Vout**: voltage analogue output;
- **Fault**: error signal, for example for cable integrity check.

The Fault signal is only available for T11 current analogue output.

To connect the fault signal, refer to the "4.6.5 Fault output (T11 order code only)" section on page 15 and see the Figure 1 and Figure 2, pay attention to R2 value.

No encoder error = transistor ON (conducting).

Encoder error = transistor OFF (open).

4.6.4 Input signals description

- **+13Vdc +30Vdc, 0Vdc:** encoder power supply;
- **START:** the same as the START ► key; it is active at HIGH logic level (voltage greater than 10V must be applied). For any further information on using the START ► and STOP ■ keys and the relevant input signals refer to the "TEACH-IN procedure" section on page 18;
- **STOP:** the same as the STOP ■ key; it is active at HIGH logic level (voltage greater than 10V must be applied). For any further information on using the START ► and STOP ■ keys and the relevant input signals refer to the "TEACH-IN procedure" section on page 18.

4.6.5 Fault output (TI1 order code only)

4.6.5.1 Fault output connected to a PLC input

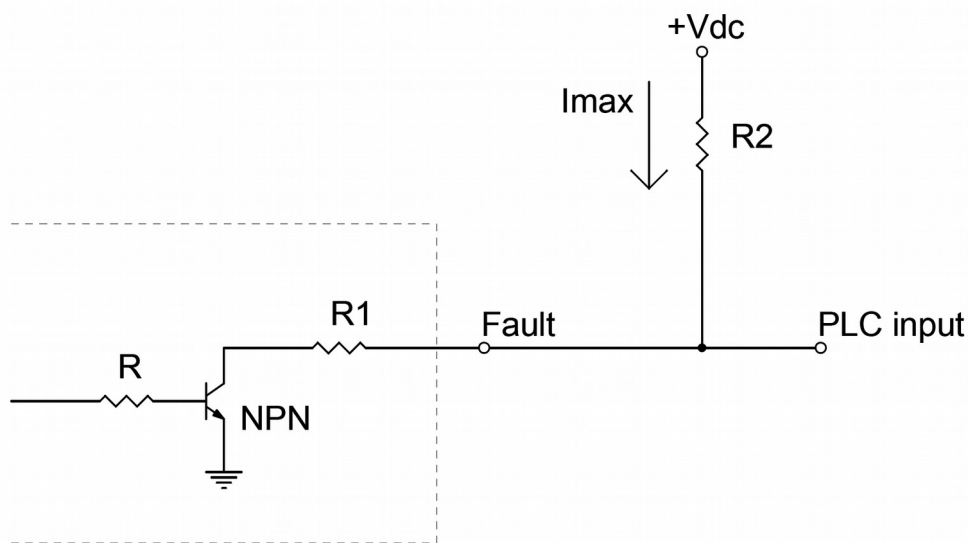

Figure 1



EXAMPLE

$1K\Omega < R2 < 10K\Omega$

No encoder error = PLC input Low (0 Vdc).

Encoder error = PLC input High (+Vdc).

4.6.5.2 Fault output connected to a relay

$I_{max} = 50\text{mA}$

$R1 = 47\Omega$

$R2 = \left(\frac{V_{dc}}{I}\right) - R1$

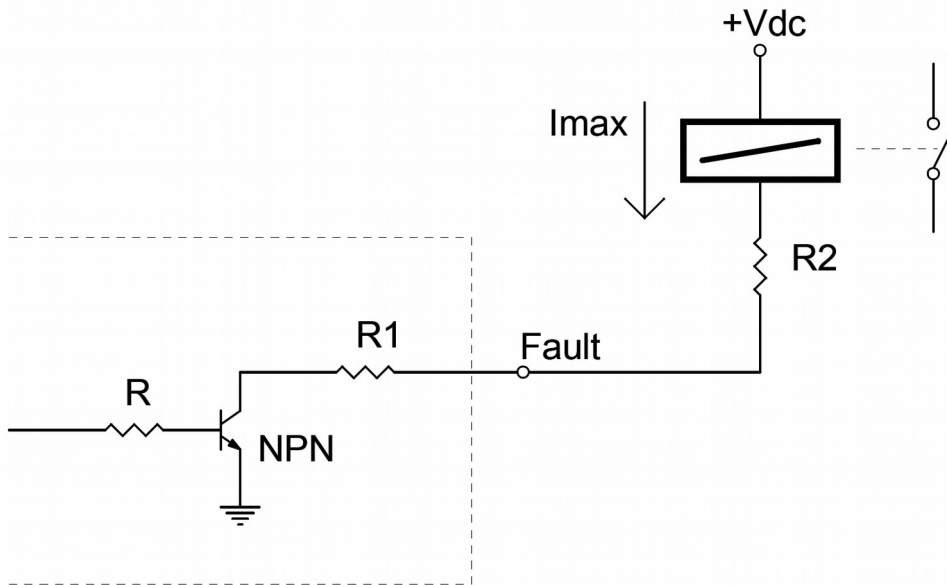

Figure 2



EXAMPLE

$V_{dc} = +24\text{V}$

$I = 30\text{mA}$ (current needed to energize a small relay coil)

$R2 = 750\Omega$

No encoder error = coil energized.

Encoder error = coil de-energized.

4.7 Recommended circuit

4.7.1 Current analogue output

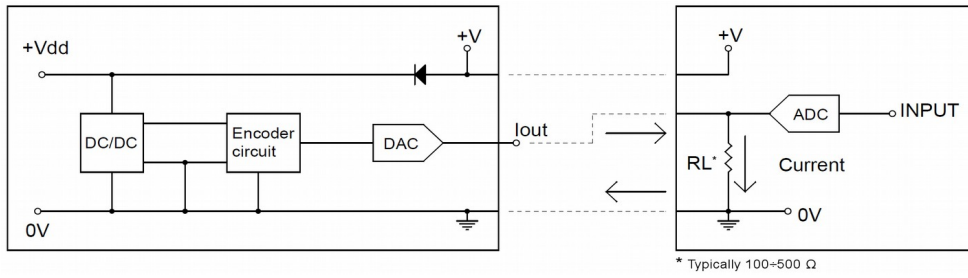

4.7.2 Voltage analogue output

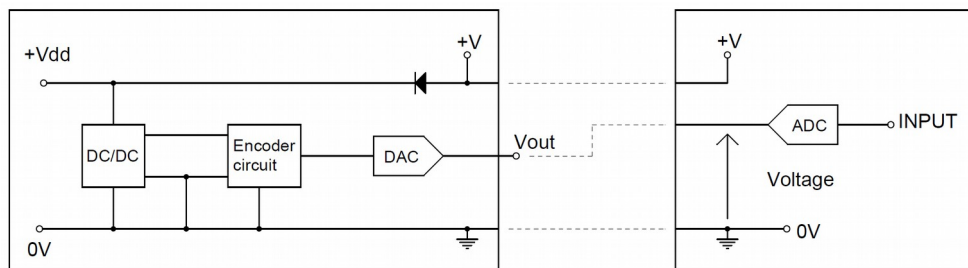

5 TEACH-IN procedure

The TEACH-IN function allows to easily and intuitively set (by means of two keys or, as an alternative, two external signals) both the furthestmost points in the travel of an axis, then the available analogue range will be scaled automatically within the set limits.

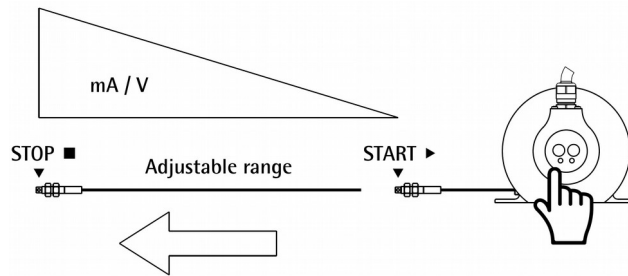

5.1 Commissioning

The TEACH-IN procedure can be executed both by pressing the two keys in the encoder enclosure and by means of the two START and STOP inputs.

To start the TEACH-IN procedure and use the keys, simultaneously press both START ► and STOP ■ keys and hold them down for 5 seconds (be careful not to exceed 10 seconds; see the "5.4 Restoring the factory default settings" section on page 22); both LEDs I and II light up solidly. As soon as the keys are released both LEDs start blinking.

Likewise, you can enter the TEACH-IN procedure by applying for 5 seconds a voltage greater than 10V to both START and STOP inputs (see the "Electrical connection" section and the "4.6.4 Input signals description" section for more details).

The analogue output is disable while executing the procedure.





NOTE

You are allowed to set the START position first and then the END position of the travel by pressing the START ► key first and then the STOP ■ key (see the Figure below); otherwise you can do the opposite, i.e. you can set the END position first and then the START position of the travel by pressing the STOP ■ key first and then the START ► key.

Moreover you can choose to have an increasing ramp when you pull the wire out, so you must press the START ► key when the wire is reeled and press the STOP ■ key when the wire is unreeled; on the contrary you can choose to have an increasing ramp when you rewind the wire, so you must press the START ► key when the wire is unreeled and press the STOP ■ key when the wire is reeled.

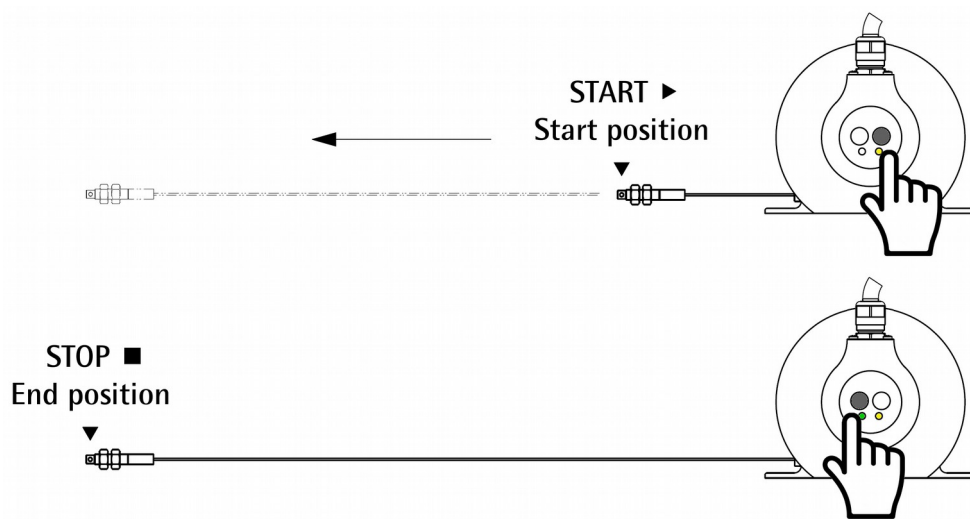

- Move the steel wire to your START position (or to the END position, see the NOTE above) in the travel of the application;
- press the START ► key for 2 seconds; LED I will light up, LED II will keep on blinking;



WARNING

From now on exit is inhibited until completion of the process.

- now move the steel wire to your END position (or to the START position, see the NOTE above) in the travel of the application;
- press the STOP ■ key for 2 seconds; LED II will light up; the analogue output will be enabled again; releasing the keys causes the LEDs to signal the normal operation with user settings (LED I = ON; LED II = OFF).



NOTE

Should the START position (START ►) be the same as the end position (STOP ■), in other words, you do not change the axis position when you press the keys, unit resets and restores the factory default settings (see the "5.4 Restoring the factory default settings" section on page 22).

5.2 OVERRUN function

5.2.1 Overrun function with TI1 order code

The TI1 order code encoder implements the OVERRUN function which operates as a limit switch and allows to detect an overtravel position by decreasing or increasing the output value beyond the analogue range.

After programming is completed, the system calculates the lowest power of 2 among which the set travel is included. Then it aligns the set travel to the centre of the longest travel resulting from the power of 2 and evenly distributes the difference between the lengths to both sides; thus it sets the low limit overtravel area and the high limit overtravel area. In both overtravel areas, the analogue output value will be easily distinguishable from the normal output range. In the example shown in the Figure 3 below the TI1 4-20 mA analogue encoder is programmed to run a 5-revolution travel **A** (1.5 ... 6.5, 9.5 ... 14.5). The set travel **A** is aligned to the centre of the longest travel resulting from the lowest power of 2 among which it is included (i.e. 8 revolutions). The difference between the travels, i.e. 3 revolutions, is evenly distributed between the low limit overtravel area **B** and the high limit overtravel area **C**. The low limit overtravel area **B** is 1.5-revolution long and provides a 3.6 mA analogue output value; while the high limit overtravel area **C** is 1.5-revolution long and provides a 22 mA analogue output value.

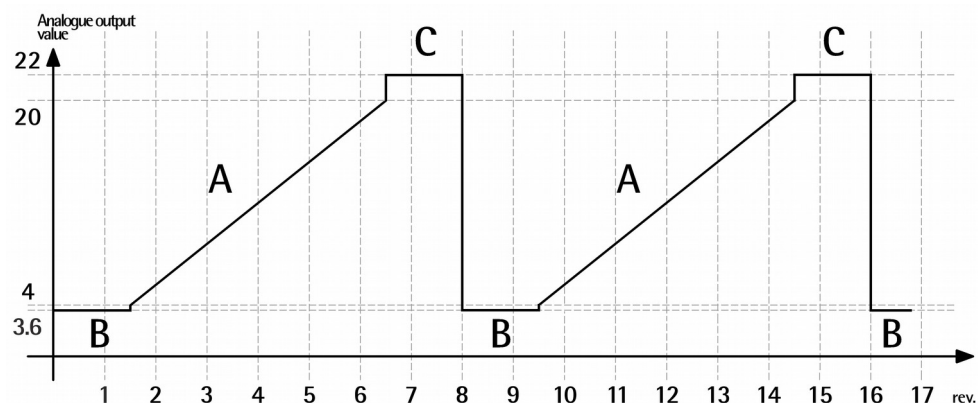

Figure 3

5.2.2 Overrun function with TV1 and TV2 order codes

In the TV1 and TV2 order code encoders, the OVERRUN function operates as described for T11 order code encoders but the overtravel position is defined by keeping for a certain space (number of revolutions) the minimum / maximum output value available in the analogue range; thus the output value does not decrease or increase beyond the analogue range.

After programming is completed, the system calculates the lowest power of 2 among which the set travel is included. Then it aligns the set travel to the centre of the longest travel resulting from the power of 2 and evenly distributes the difference between the lengths to both sides; thus it sets the low limit overtravel area and the high limit overtravel area. In the low limit and high limit overtravel areas, the analogue output value will be kept at the minimum and maximum value of the output range respectively. In the example shown in the Figure 4 below the encoder is programmed to run a 5-revolution travel **A** (1.5 ... 6.5, 9.5 ... 14.5). The set travel **A** is aligned to the centre of the longest travel resulting from the lowest power of 2 among which it is included (i.e. 8 revolutions). The difference between the travels, i.e. 3 revolutions, is evenly distributed between the low limit overtravel area **B** and the high limit overtravel area **C**. The low limit overtravel area **B** is 1.5-revolution long and provides the minimum value available in the analogue range; while the high limit overtravel area **C** is 1.5-revolution long and provides the maximum value available in the analogue range.

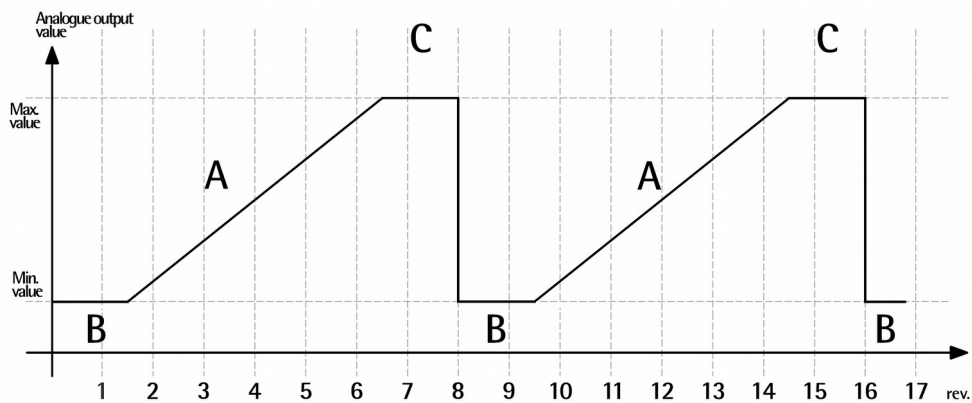

Figure 4

5.3 Aborting the TEACH-IN procedure

The TEACH-IN procedure can be aborted only before setting the START position. Otherwise you must complete the process before exiting. Simultaneously press both START ► and STOP ■ keys to abort the TEACH-IN procedure. The unit will

be restored to the previous working condition before starting the TEACH-IN procedure, signalled through LEDs.



WARNING

After having set either limit in the application travel it is forbidden to exit the TEACH-IN procedure before completion.

5.4 Restoring the factory default settings



WARNING

Fully wind the wire before accomplishing the operation.

Simultaneously press both START ► and STOP ■ keys and hold them down for 10 seconds. Both LEDs light up solidly after about 5 seconds. After 10 seconds all parameters will be set to defaults, LED I switches off while LED II stays lit (working operation with default settings, see the "5.5 Function of the LEDs" paragraph). With default values, the START position begins after the wire is unwound 50 mm (they are calculated starting from wire fully wound) and the analogue value in the first 50 mm is the low limit overrun value; the analogue range is scaled in a 5000 mm travel for SFA-5000; in a 10000 mm travel for SFA-10000. Positive counting by unwinding the wire.

5.5 Function of the LEDs

Two LEDs are located just above the keys, they are designed to show visually the current working mode and the operational state of the encoder as explained in the following table.

LED I	LED II	Description
ON	OFF	Normal operation with user settings
OFF	ON	Normal operation with factory default settings
ON	ON	Entering the TEACH-IN procedure, both START ► and STOP ■ keys have been pressed for 5 seconds
Flash	Flash	Entering the TEACH-IN procedure, both START ► and STOP ■ keys have been released after 5 seconds
ON	Flash	During the normal TEACH-IN procedure (i.e. starting

		from the initial position), the initial position has been set by pressing the START ► key
Flash	ON	During the inverted TEACH-IN procedure (i.e. starting from the final position), the final position has been set by pressing the STOP ■ key

5.6 Times and functions

When you press both or just one key for a given time, you will activate a specific function. In the following table actions and times to activate the implemented functions are listed.

Action	Time (sec.)	Function	LED
Both START ► and STOP ■ keys pressed	10	The encoder is reset and factory default settings are restored	After 5 sec. both LEDs light up solidly, after 10 sec. LED I = OFF, LED II = ON
Both START ► and STOP ■ keys pressed	5	Enter the TEACH-IN procedure	After 5 sec. both LEDs light up solidly, they start blinking at key release
START ► key pressed	2	Set the initial position of the travel	Both LEDs are blinking; after pressing the START ► key for 2 seconds, LED I lights up solidly, while LED II keeps on blinking
STOP ■ key pressed	2	Set the final position of the travel	LED I is solidly lit, LED II is blinking; after pressing the STOP ■ key for 2 seconds also LED II lights up solidly. At key release LED II switches off



Document release	Description
1.0	1 st issue
1.1	Default setting instructions updated ("5.4 Restoring the factory default settings" section)
1.2	New membrane keys



Dispose separately



LIKA Electronic
Via S. Lorenzo, 25
36010 Carrè (VI) • Italy
Tel. +39 0445 806600
Fax +39 0445 806699

Italy: eMail info@lika.it - www.lika.it
World: eMail info@lika.biz - www.lika.biz